

Continuous support systems

# FLAT LOCK SEAM

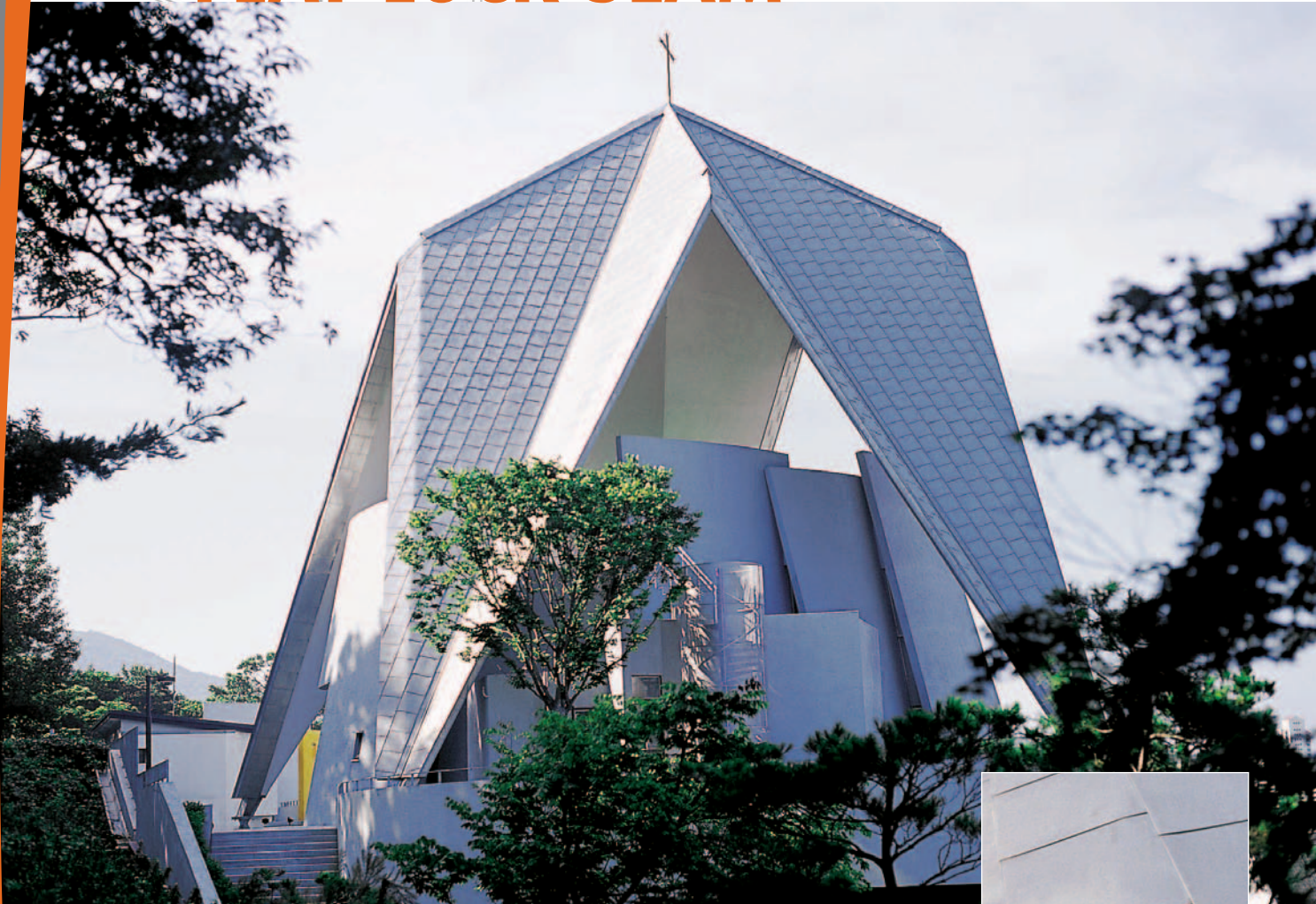

Chong Yang Church, Chong Yang-Ku (South Korea) - Architect(s): Geonchook - Contractor(s): Sunnie International

- Horizontal, vertical and diamond shaped cladding
- Versatile system with a classical look
- Recessed joints with concealed fastening
- Range of components offering a wide variety of flashing details.

A Umicore brand





# Description of the system

The Flat Lock system can easily be installed for both new and refurbishment projects. It involves laying the panels on a continuous support fixed to the supporting structure (masonry or metal structure). A simple fold is interlocked on all four sides and can be installed in either horizontal or vertical orientations. Flat Lock panels offer a simple yet elegant cladding solution that provides a longitudinal flat seam.



Flat Lock panels are manufactured in 0.7 mm and 0.8 mm. The panels can be laid vertically, horizontally and as a diamond shape. The choice of direction implies different aesthetics and technical solutions for the main flashings.

## ■ Flat Lock seam panels

The Flat Lock system consists of a wall system of factory-formed panels.

The rectangular-shaped panels interlock into each other on the four sides. The panels are then secured with concealed fasteners and clips.

The flat lock panels can be preformed with a recessed joint or a non recessed joint (see section below).

Private house, Merelbeke (Belgium)

Architect(s): Bureau d'architecture Rauw - Contractor(s): CU ZN

## Recessed joint

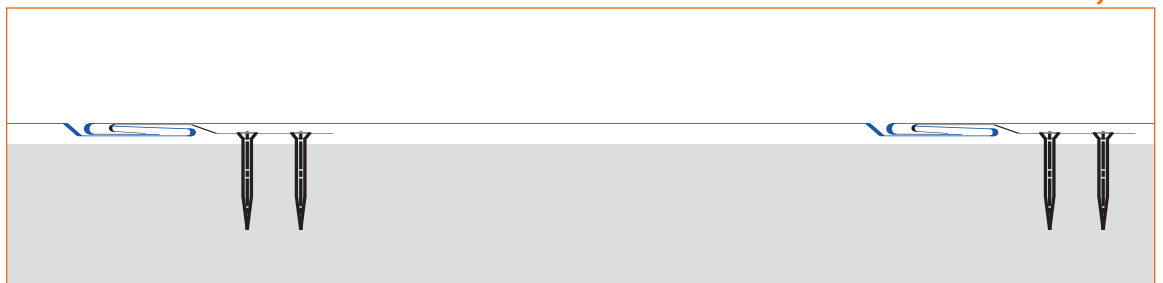

## No recessed joint

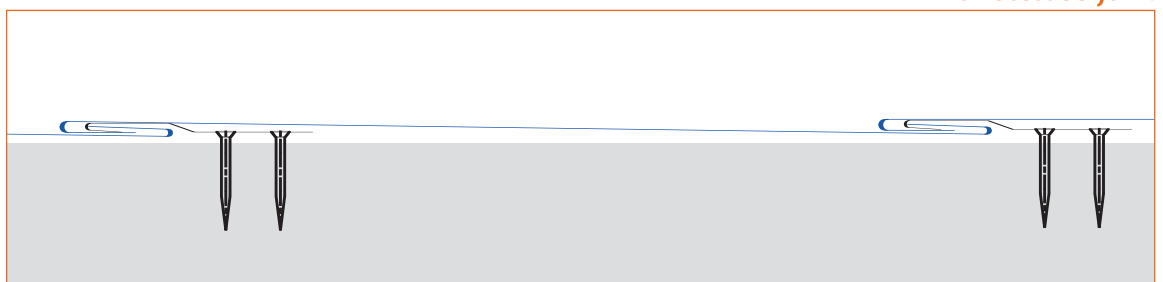

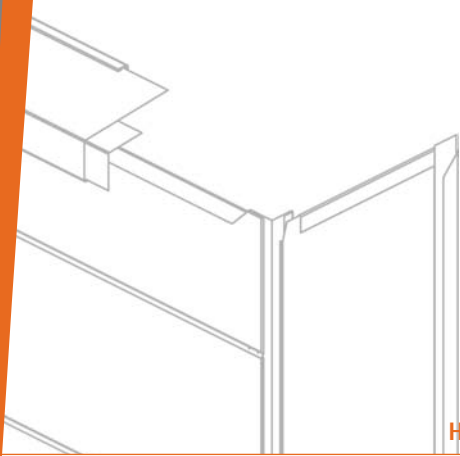

Horizontal panel

Vertical panel

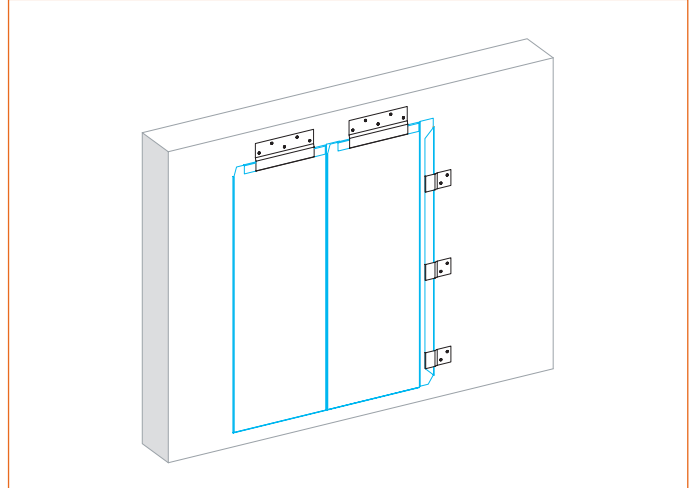
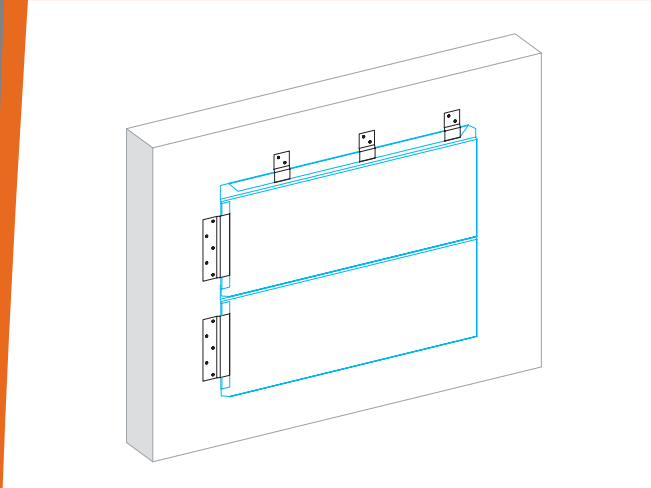

Secondary School Ampère, Morsang sur Orge (France) - Architect(s): Lombard, Bertholon, Seher

Flat lock panels are available in different centre-to-centre distances (Visible panel face + joint width = centre-to-centre distance of the panel).

This system is supplied in lengths determined by the layout scheme, which can vary to a maximum of 3 m.

**Specifications**

Thickness	0.7 mm - 0.8 mm
Length	to 3 m
Centre-to-centre	from 100 mm to 375 mm
Weight* Kg/m <sup>2</sup>	8 kg/m <sup>2</sup>

\* Weight of the zinc/m<sup>2</sup> excluding framework

**Fixing**

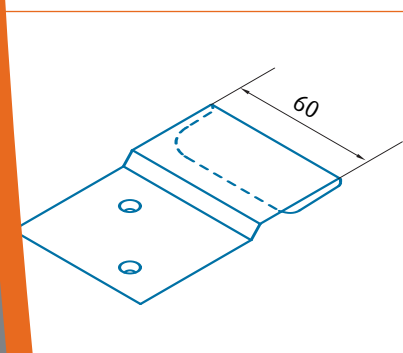

Fixing clip

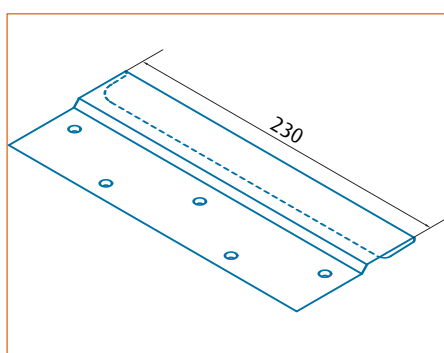

Fixing strip

There are two types of fixing elements for Flat Lock Seam:

- On the long side, a 0.5 mm thick galvanised steel fixing clip is used
- On the short side, a 0.5 mm thick galvanised steel fixing strip is used
- Each flat lock system is fixed to the support using 3 clips per linear metre.

# Area of application

## ■ Type of facade

Flat facades.

## ■ Climate

All climates.

For buildings higher than 30 meters with high wind-load, please consult VM ZINC®.

## ■ Support

It must be rigid and continuous for all parts where VM ZINC® is installed: under panels as well as under flashing. There should be no more than a 5 mm difference in height (flush tolerance) between its components at their junction.

There should be no protruding elements on the support, e.g., screws or nails that could damage the underside of the zinc.

The support must also meet loading requirements in compliance with the national code of practice, have a minimum pull-out strength of 50 daN for each of the fixing systems, provided that the entire support transmits the cumulated load to the structure.

## ■ Admissible resistance

In order to respond to major loads due to wind suction that could occur in some parts of the building (verge, corner, edges), the fixing clips may be increased. Wind loads and weather conditions for a specific location or structure will determine the best criteria for this system.

MBC Tower, Daegu (South Korea)  
Architect(s): Ilkun



# Details

- 1 VM ZINC® window flashing
- 2 Galvanized strip
- 3 Folded strip
- 4 Vertical VM ZINC® Flat Lock panel
- 5 Galvanized sheet clip
- 6 Corner flashing in VM ZINC®
- 7 Horizontal VM ZINC® Flat Lock panel
- 8 VM ZINC® inverted flat slider
- 9 Galvanized strip
- 10 VM ZINC® window sill flashing
- 11 Galvanized strip
- 12 VM ZINC® window sill flashing
- 13 Galvanized strip
- 14 VM ZINC® acute corner flashing

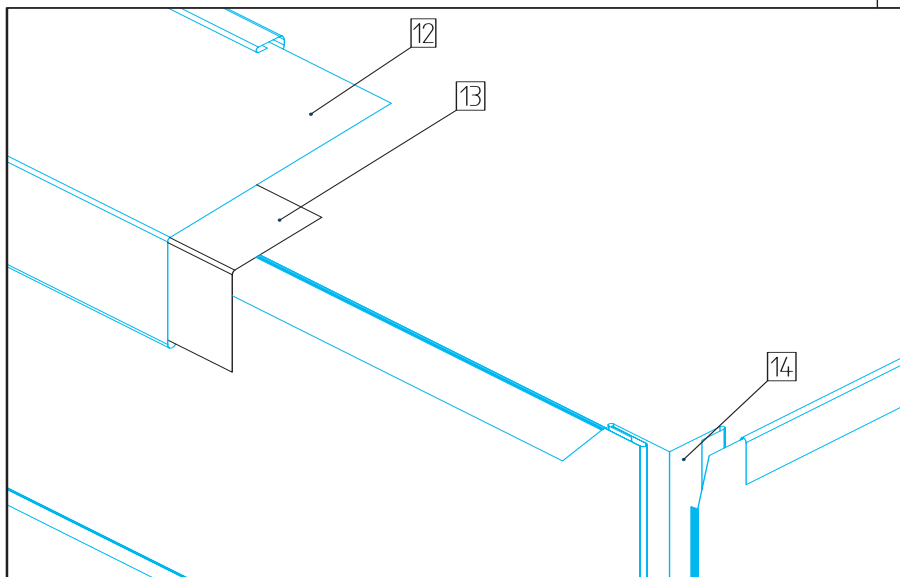
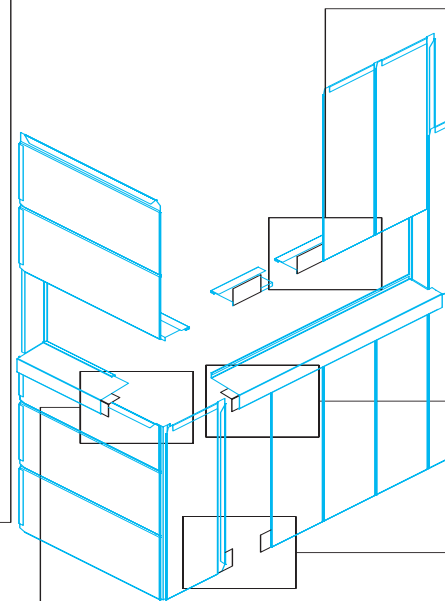
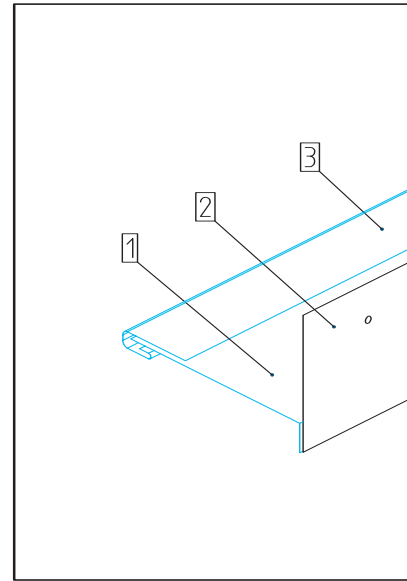

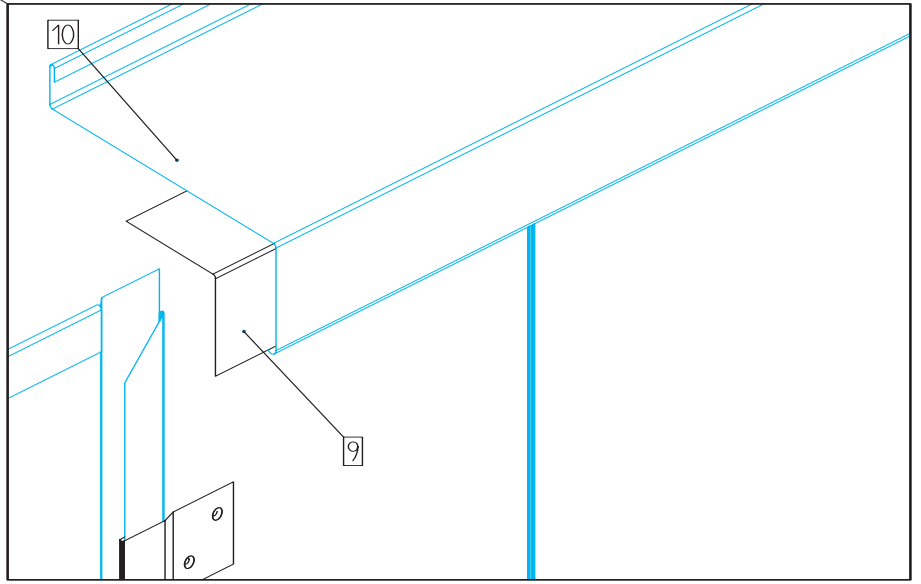
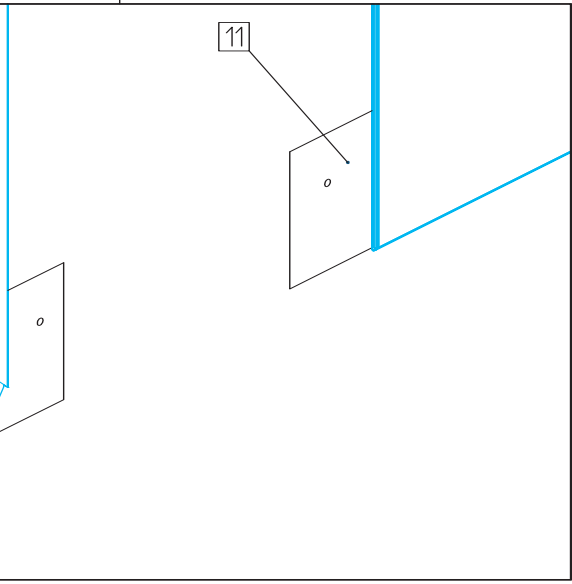
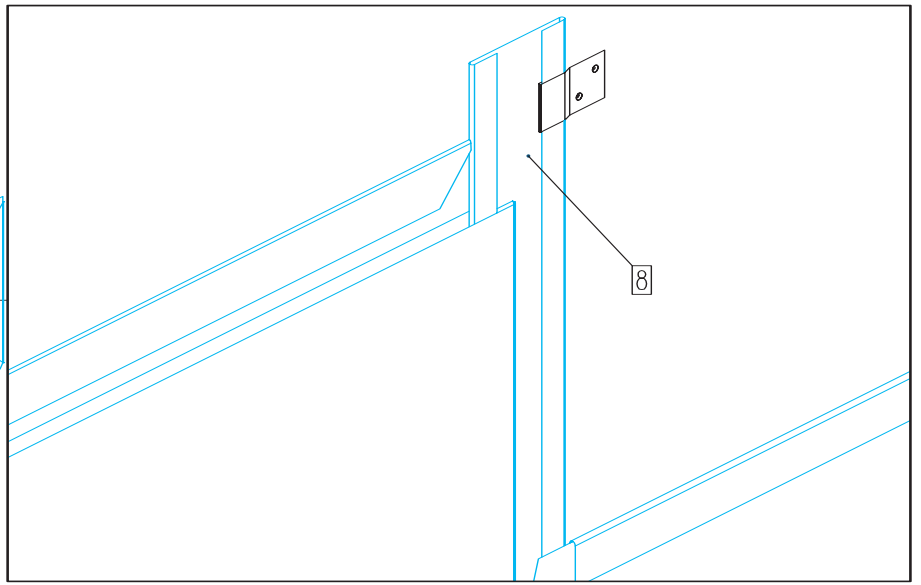
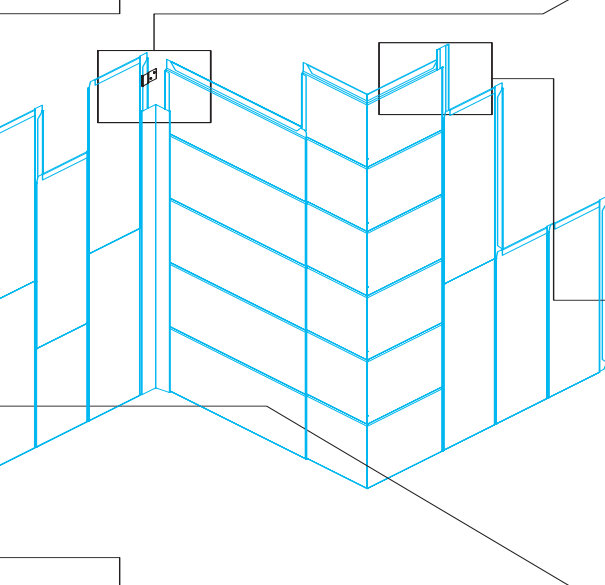
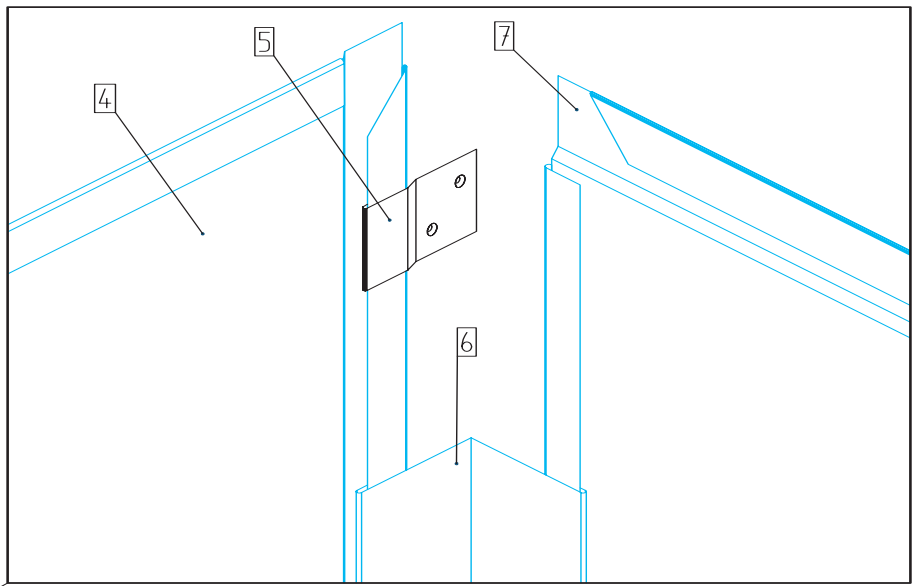
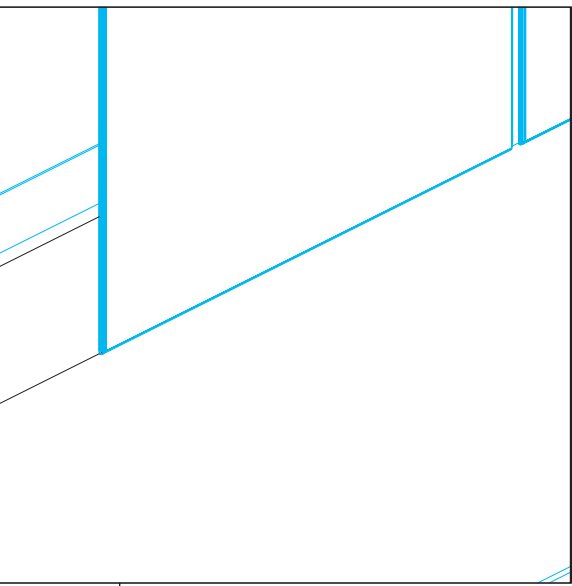

The sole purpose of this document is to describe the main technical characteristics of VM ZINC® products manufactured by Umicore.

The specification and installation of these products are the sole responsibility of the architects and building professionals who must ensure these products are used in a way suited to the end purpose of the construction and that they are compatible with other products and techniques used.

The specification and installation of the products implies respecting the standards in force and the manufacturer's recommendations. In this regard, Umicore publishes and regularly updates specification and installation manuals for specific geographic areas and provides training courses. All the information on the latter can be obtained from the local VM ZINC® team.

Umicore can not be held responsible for any specification or use of its products that has not respected all these standards, recommendations and practices.

#### Beijing

Umicore Marketing Services  
Building Products  
Room 502, Xinghua Business Centre,  
#11, Xinghua Lu, Heping Li, Eastern City District  
Beijing 100013, China  
Tel.: + 86 10 6424 6721 - Fax: + 86 10 6424 6762  
Email: vmzinc.china@ap.umicore.com  
www.vmzinc.com

#### Shanghai

Umicore Marketing Services Co., Ltd.  
Building Products  
Unit A1,18/F, Zao-Fong Universe Building,  
No.1800 West, Zhongshan Road,  
Shanghai 200233, China  
Tel.: + 86 21 6440 1100 - Fax: + 86 21 6888 0088  
Email: vmzinc.china@ap.umicore.com  
www.vmzinc.com

#### Hong Kong

Umicore Marketing Services  
Building Products - Unit A-B 19/F  
Manulife Tower, 169 Electric Road - North Point  
Hong Kong  
Tel.: + 852 2700 2268 - Fax: + 852 2882 1990  
Email: vmzinc.hongkong@ap.umicore.com  
www.vmzinc.com

#### Singapore

Umicore Pte Ltd  
Building Products - No. 2, Corporation Road  
# 06-16/17 Corporation Place (Lobby A)  
Singapore 618494  
Tel.: +65 6898 3936 - Fax: +65 6265 7118  
Email: vmzinc.singapore@ap.umicore.com  
www.vmzinc.com

#### Taiwan

Umicore Marketing Services Co., Ltd.  
Building Products  
16F-2, No. 189, Keelung Road, Sec. 2, Taipei  
11054 Taiwan, R.O.C.  
Tel.: + 886 2 8732 2021 - Fax: + 886 2 8732 2026  
www.vmzinc.com

